

**Basic Instructions only!**  
For more detailed product information, refer to the  
**AirPro Locker Installation and Owner's Instructions 241A564 or  
AirPro Double Tier Locker Installation and Owner's Instructions 241B121**

**CAUTION**  
*Make sure anyone assembling, installing or using this product has read and understands these instructions.*

**CAUTION**  
*Failure to comply with Warnings and Cautions in this document or on the equipment can result in damage to property or serious injury.*

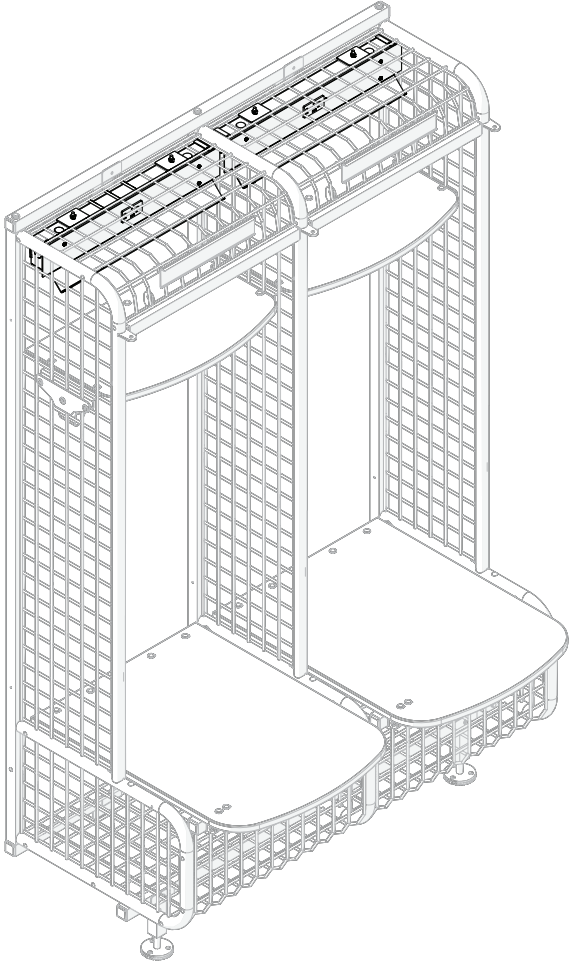

Visit the GearBoss AirPro Locker web page at [gearboss.com](http://gearboss.com) for more information.

**Note:** Please read and understand these instructions before proceeding.  
**Note:** If you need additional information, contact Wenger Corporation using the information below.

## Required Tools

- 7/16" Combination wrench
- Phillips screwdriver

## Installation

1. One electrical kit will be installed per locker and they may be wired together.  
Check with local officials regarding code requirements before installing.  
**Wenger Corporation suggests not wiring more than five outlet boxes together/per circuit.**
2. Start at the first locker and attach an outlet box to the inside rear of the top grilles using two connect plates, 1/4-20 x 3/4" carriage bolts and 1/4-20 lock nuts.

**STOP**

*Each additional electrical kit will be connected using an included UL approved 2" box spacer that must be attached to the adjoining outlet box before it is mounted.*

*See Step 3 on the following page before mounting additional outlet boxes.*

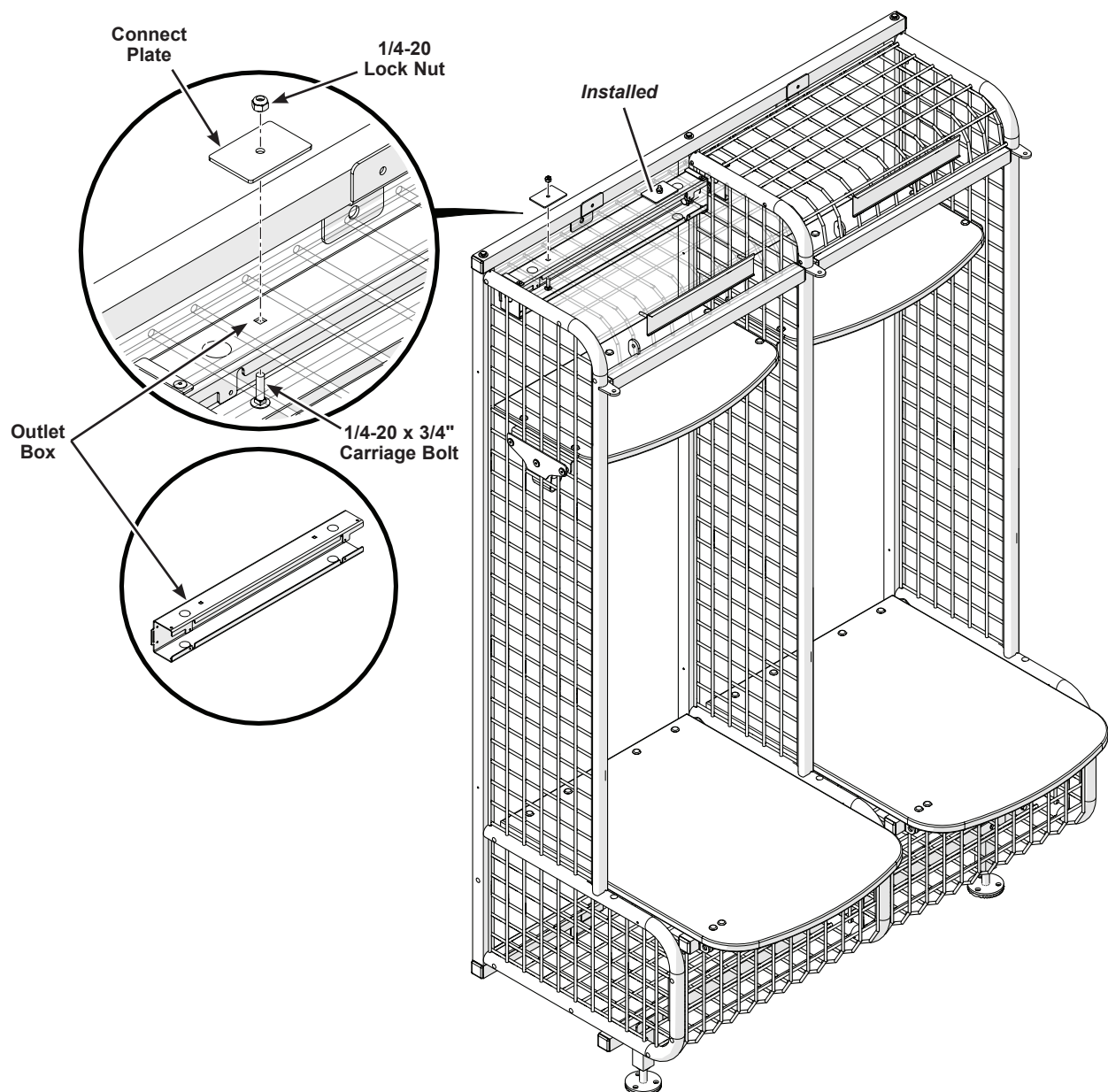

## Installation (continued)

3. Make the electrical connections using a licensed electrician.  
There are several openings in the outlet box to route power through.
  - a. Outlet boxes may be connected together by removing the "knock-outs" and using UL approved electrical metallic tubing (emt) connectors. Knock-outs must not be removed unless a connection is made to another unit.  
For convenience, a UL approved 2" box spacer has been provided (Garvin® BB-1/2-2).  
**Wenger Corporation suggests not wiring more than five outlet boxes together/per circuit.**  
**Connect an adjoining outlet box before mounting it into to the next locker.**
  - b. Repeat Steps 2 and 3 to attach and connect the next outlet box before proceeding to Step 4.

**⚠ WARNING**  
A licensed electrician must perform the electrical installation.

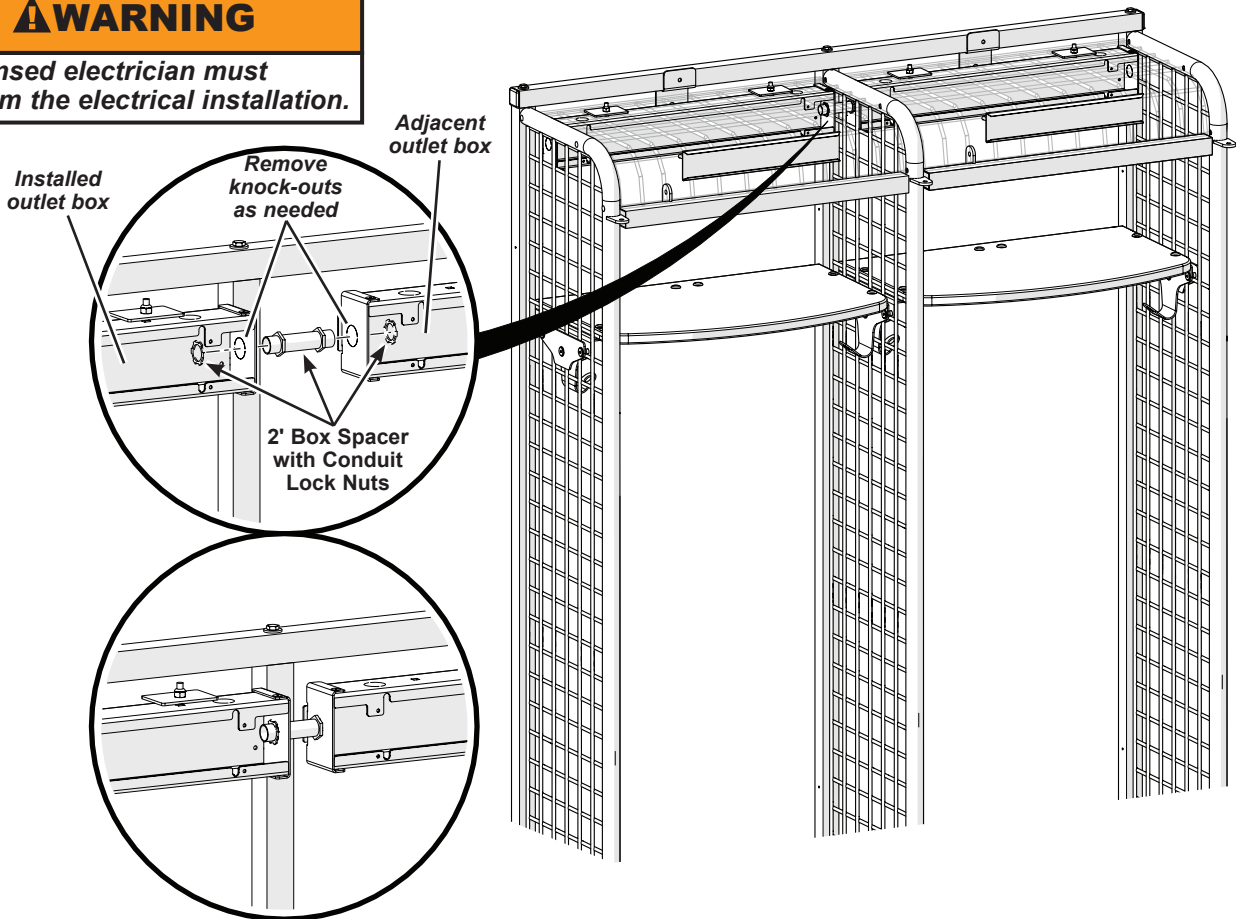

4. Attach the front bracket to the receptacle using two 6-32 x 3/8" machine screws and two 6-32 jam lock nuts.

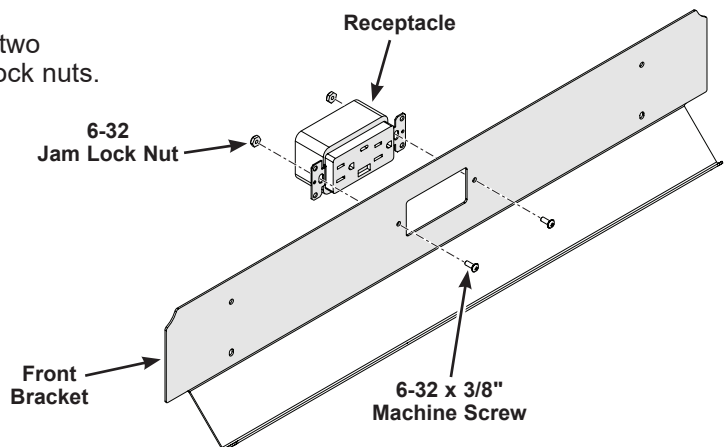

## ***Installation (continued)***

5. Attach the front bracket to the outlet box using four 8-32 x 3/16" machine screws.

